

| | | | | | | | |
|-----------------|------------------|------------------|------------------|----------|---------------------|--|---|
| Line-No. | Date | 27.02.2012 | Order-No. | | Amount | | Supplier Laserpack Fryazino Die-Side |
| | Path | aserpack/filesW | Author | Yashin A | Height | | |
| | File | a> ECMA_A2220.cd | Customer | | Manufacturer | | |
| | 10/15/18 | | Line type | | Material | | |
| | Sonstiges | | Pointage | | Mat. Table | | |

Rule Processing System ACS 100 for ISO 9000

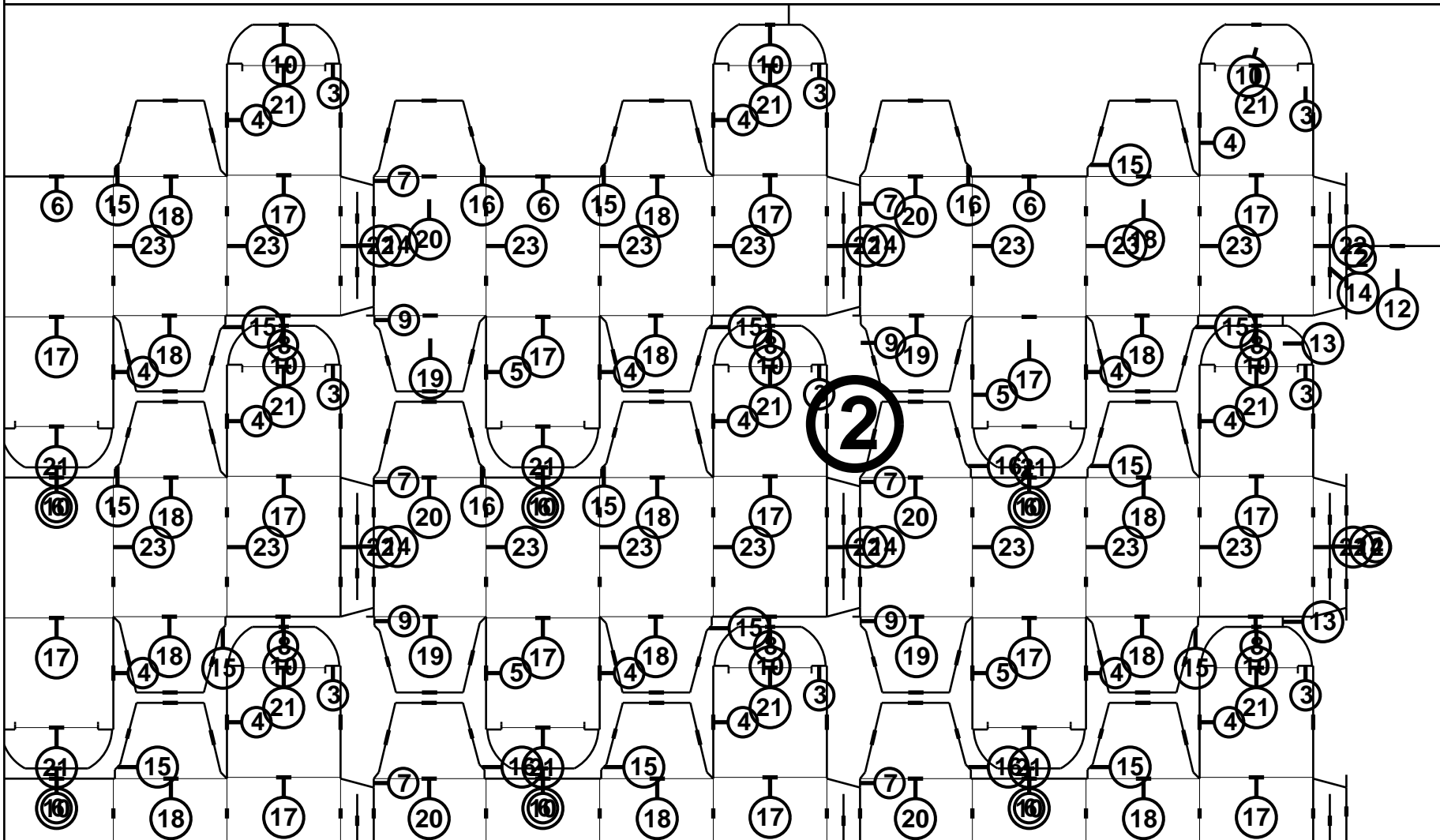

| | | | | | | | |
|----------|-----------|-----------------|-----------|----------|--------------|----------|-------------------------------|
| Line-No. | Date | 27.02.2012 | Order-No. | | Amount | | Supplier |
| | Path | aserpack/filesW | Author | Yashin A | Height | | Laserpack Fryazino |
| | File | a> ECMA_A2220.d | Customer | | Manufacturer | | |
| | 10/15/18 | | Line type | | Material | | |
| | Sonstiges | | Pointage | | Mat. Table | | |
| | | | | | | Die-Side | |

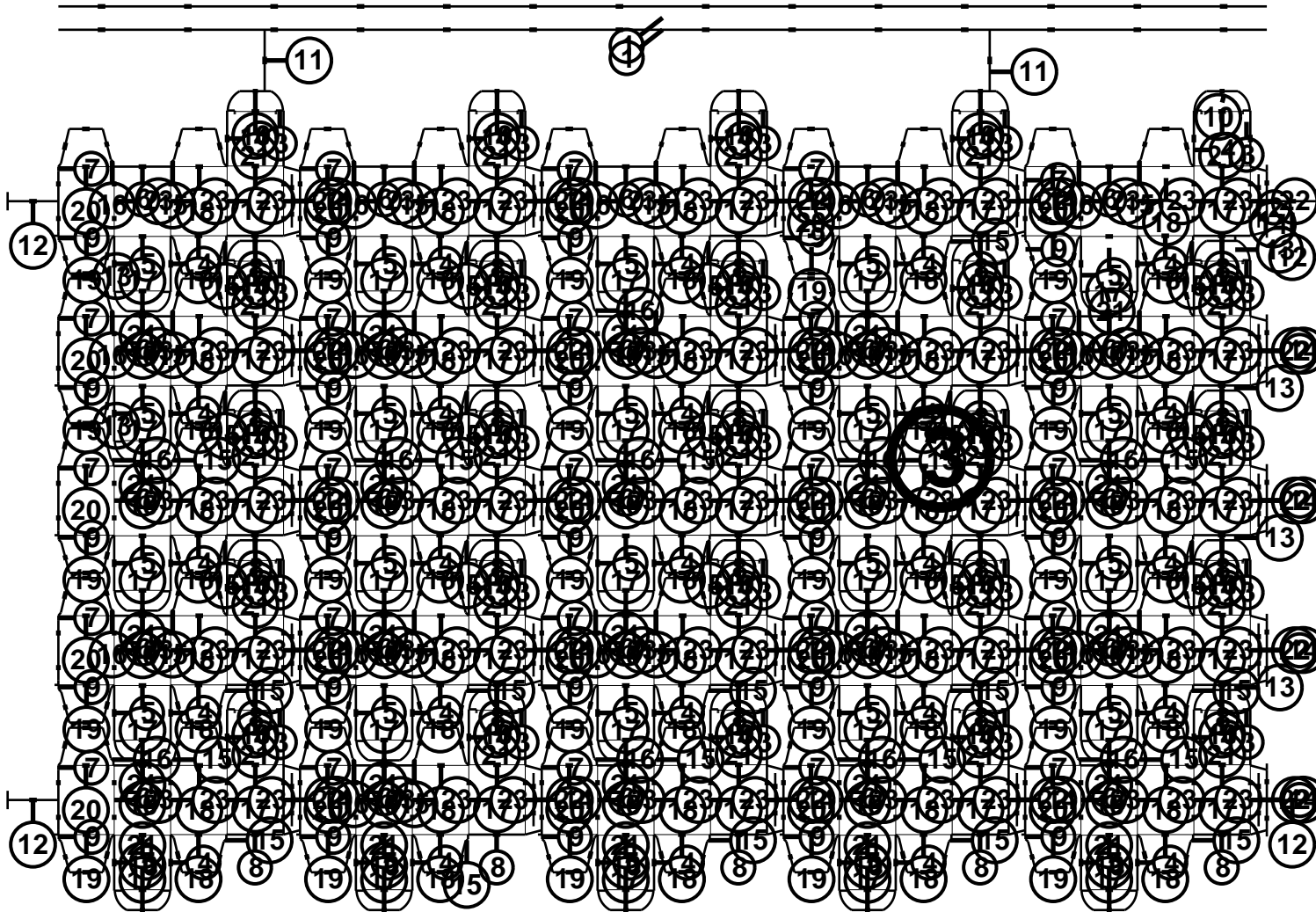

| | | | | | | | |
|----------|-----------|------------------|-----------|----------|--------------|----------|-------------------------------|
| Line-No. | Date | 27.02.2012 | Order-No. | | Amount | | Supplier |
| | Path | aserpack/filesW | Author | Yashin A | Height | | Laserpack Fryazino |
| | File | a> ECMA_A2220.cd | Customer | | Manufacturer | | |
| | 10/15/18 | | Line type | | Material | | |
| | Sonstiges | | Pointage | | Mat. Table | | |
| | | | | | | Die-Side | |

Rule Processing System ACS 100 for ISO 9000

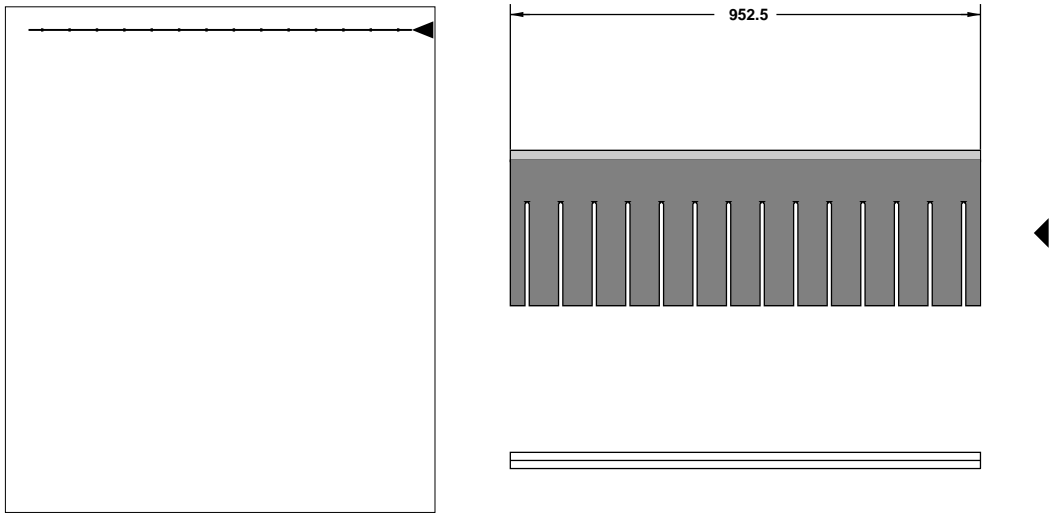

| | | | | | | | | | |
|----------|-----------|------------------|------------|-----------|--------------|---------------|----------|---------------------------|--|
| 1 | Line-No. | Date | 27.02.2012 | Order-No. | | Amount | 2 | Supplier | |
| | Path | asercpack/filesW | Author | Yashin A | Height | 23.80 | | Laserpack Fryazino | |
| | File | a> ECMA_A2220.d | Customer | | Manufacturer | Boehler | | | |
| | 10/15/18 | | Line type | Cut | Material | UNIVERSAL-T30 | | | |
| | Sonstiges | | Pointage | 2.00 | Mat. Table | 04 | Die-Side | | |

Rule Processing System ACS 100 for ISO 9000

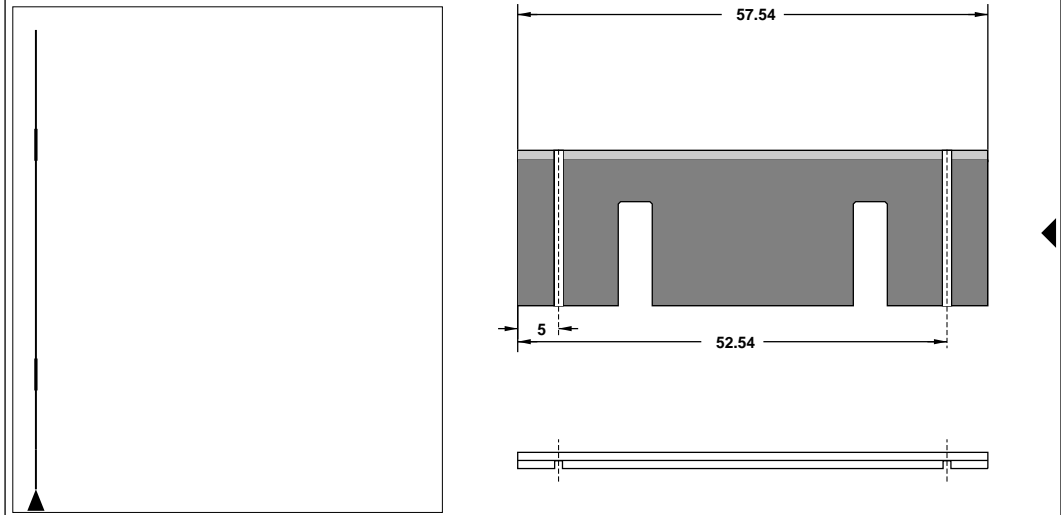

| | | | | | | | | | |
|----------|-----------|------------------|------------|-----------|--------------|---------------|----------|---------------------------|--|
| 2 | Line-No. | Date | 27.02.2012 | Order-No. | | Amount | 5 | Supplier | |
| | Path | asercpack/filesW | Author | Yashin A | Height | 23.80 | | Laserpack Fryazino | |
| | File | a> ECMA_A2220.d | Customer | | Manufacturer | Boehler | | | |
| | 10/15/18 | | Line type | Cut | Material | UNIVERSAL-T30 | | | |
| | Sonstiges | | Pointage | 2.00 | Mat. Table | 04 | Die-Side | | |

Rule Processing System ACS 100 for ISO 9000

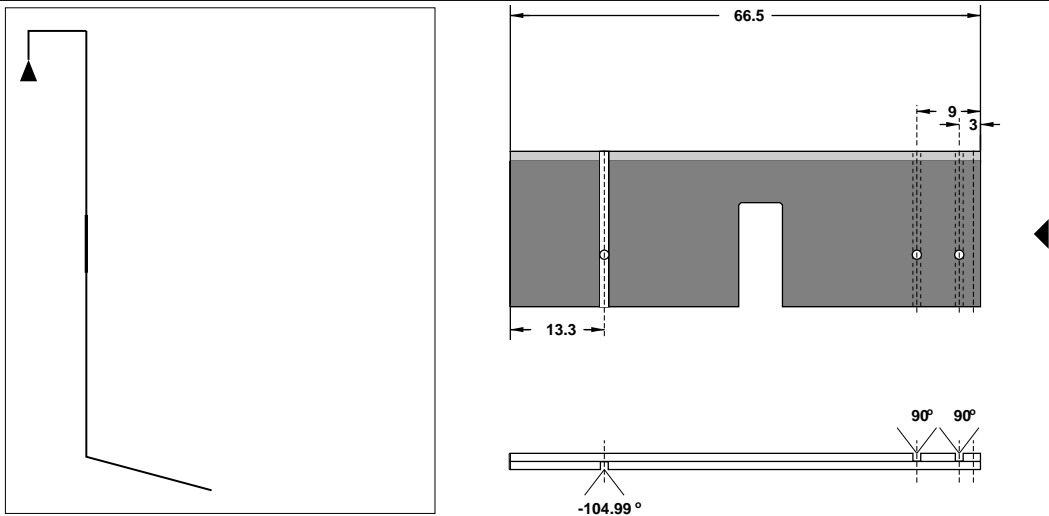

| | | | | | | | | | |
|----------|-----------|------------------|------------|-----------|--------------|---------------|----------|---------------------------|--|
| 3 | Line-No. | Date | 27.02.2012 | Order-No. | | Amount | 25 | Supplier | |
| | Path | asercpack/filesW | Author | Yashin A | Height | 23.80 | | Laserpack Fryazino | |
| | File | a> ECMA_A2220.d | Customer | | Manufacturer | Boehler | | | |
| | 10/15/18 | | Line type | PERFO | Material | UNIVERSAL-T30 | | | |
| | Sonstiges | | Pointage | 2.00 | Mat. Table | 04 | Die-Side | | |

Rule Processing System ACS 100 for ISO 9000

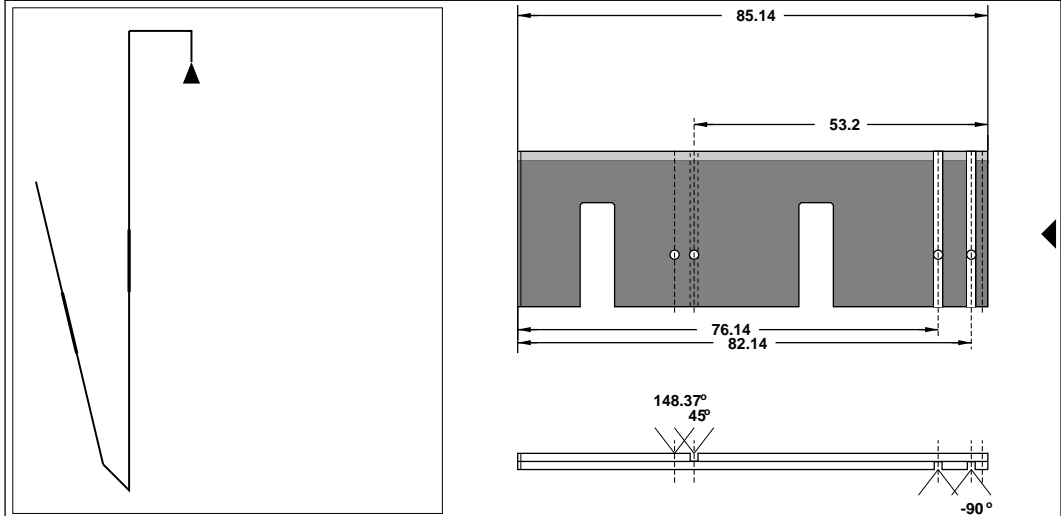

| | | | | | | | | | |
|----------|-----------|------------------|------------|-----------|--------------|---------------|----------|---------------------------|--|
| 4 | Line-No. | Date | 27.02.2012 | Order-No. | | Amount | 50 | Supplier | |
| | Path | asercpack/filesW | Author | Yashin A | Height | 23.80 | | Laserpack Fryazino | |
| | File | a> ECMA_A2220.d | Customer | | Manufacturer | Boehler | | | |
| | 10/15/18 | | Line type | PERFO | Material | UNIVERSAL-T30 | | | |
| | Sonstiges | | Pointage | 2.00 | Mat. Table | 04 | Die-Side | | |

Rule Processing System ACS 100 for ISO 9000

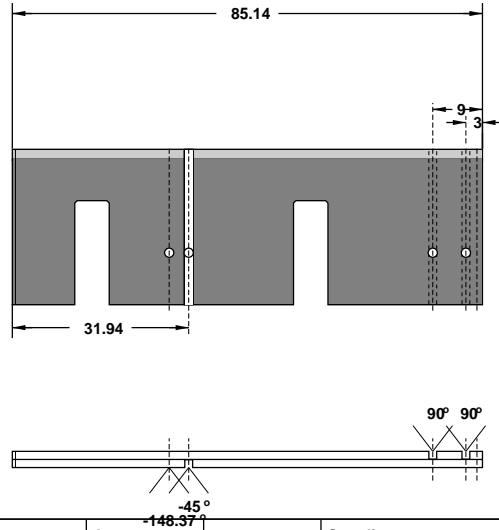
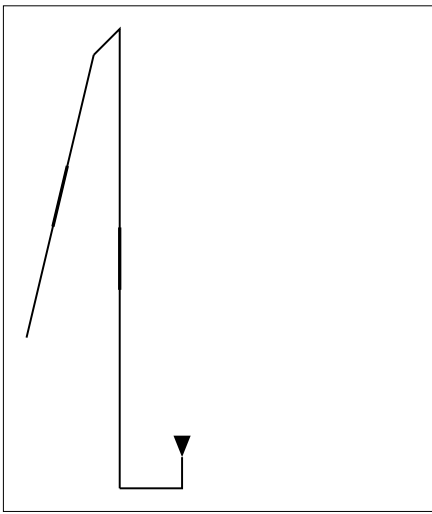

| | | | | | | | | | |
|----------|-----------|------------------|------------|-----------|--------------|---------------|---------------------------|----------|--|
| 5 | Line-No. | Date | 27.02.2012 | Order-No. | | Amount | 25 | Supplier | |
| | Path | asercpack/filesW | Author | Yashin A | Height | 23.80 | Laserpack Fryazino | | |
| | File | a> ECMA_A2220.d | Customer | | Manufacturer | Boehler | | | |
| | 10/15/18 | | Line type | PERFO | Material | UNIVERSAL-T30 | | | |
| | Sonstiges | | Pointage | 2.00 | Mat. Table | 04 | Die-Side | | |

Rule Processing System ACS 100 for ISO 9000

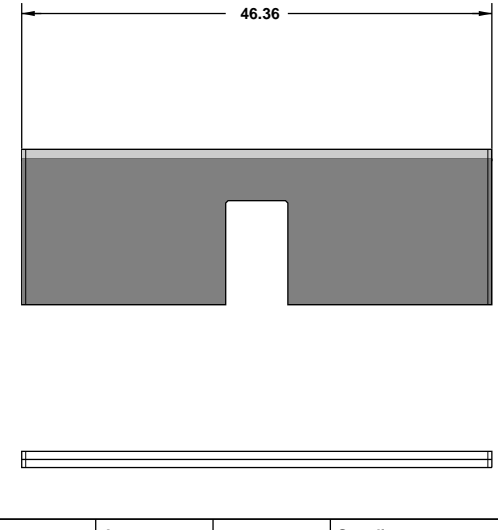
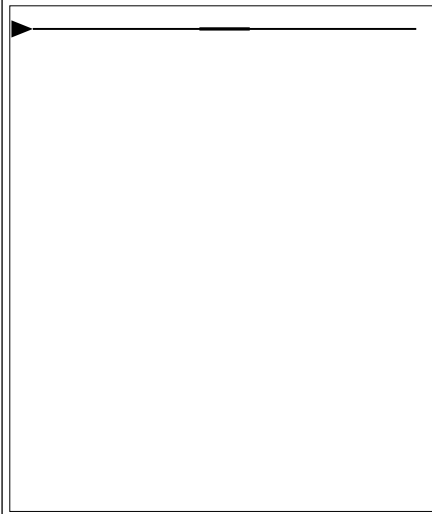

| | | | | | | | | | |
|----------|-----------|------------------|------------|-----------|--------------|---------------|---------------------------|----------|--|
| 6 | Line-No. | Date | 27.02.2012 | Order-No. | | Amount | 25 | Supplier | |
| | Path | asercpack/filesW | Author | Yashin A | Height | 23.80 | Laserpack Fryazino | | |
| | File | a> ECMA_A2220.d | Customer | | Manufacturer | Boehler | | | |
| | 10/15/18 | | Line type | Cut | Material | UNIVERSAL-T30 | | | |
| | Sonstiges | | Pointage | 2.00 | Mat. Table | 04 | Die-Side | | |

Rule Processing System ACS 100 for ISO 9000

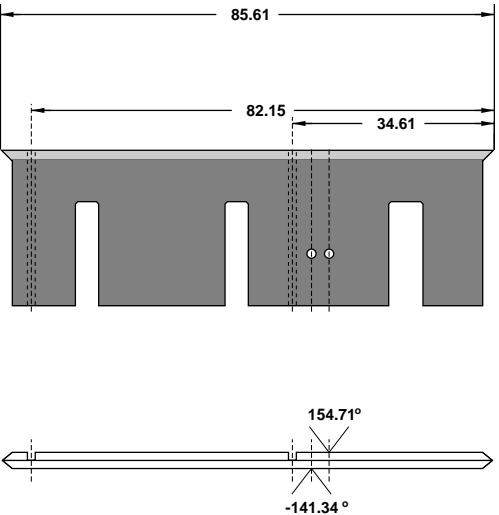
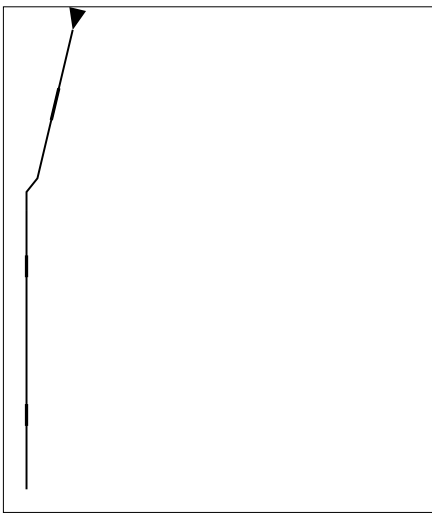

| | | | | | | | | | |
|----------|-----------|------------------|------------|-----------|--------------|---------------|---------------------------|----------|--|
| 7 | Line-No. | Date | 27.02.2012 | Order-No. | | Amount | 25 | Supplier | |
| | Path | asercpack/filesW | Author | Yashin A | Height | 23.80 | Laserpack Fryazino | | |
| | File | a> ECMA_A2220.d | Customer | | Manufacturer | Boehler | | | |
| | 10/15/18 | | Line type | Cut | Material | UNIVERSAL-T30 | | | |
| | Sonstiges | | Pointage | 2.00 | Mat. Table | 04 | Die-Side | | |

Rule Processing System ACS 100 for ISO 9000

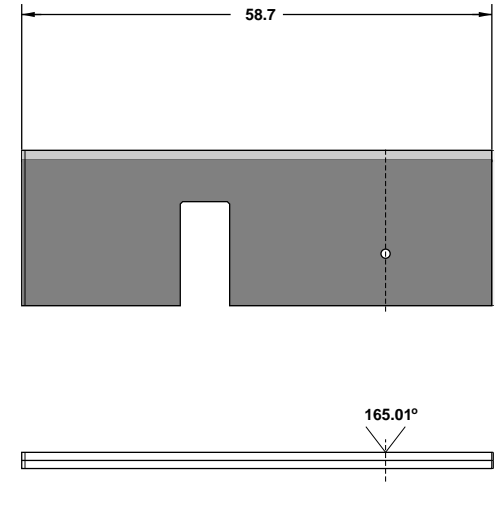
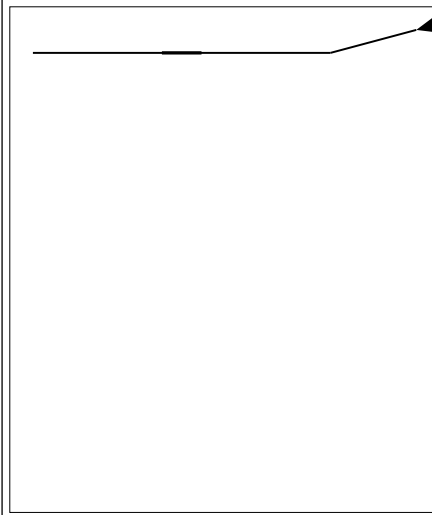

| | | | | | | | | | |
|----------|-----------|------------------|------------|-----------|--------------|---------------|---------------------------|----------|--|
| 8 | Line-No. | Date | 27.02.2012 | Order-No. | | Amount | 25 | Supplier | |
| | Path | asercpack/filesW | Author | Yashin A | Height | 23.80 | Laserpack Fryazino | | |
| | File | a> ECMA_A2220.d | Customer | | Manufacturer | Boehler | | | |
| | 10/15/18 | | Line type | Cut | Material | UNIVERSAL-T30 | | | |
| | Sonstiges | | Pointage | 2.00 | Mat. Table | 04 | Die-Side | | |

Rule Processing System ACS 100 for ISO 9000

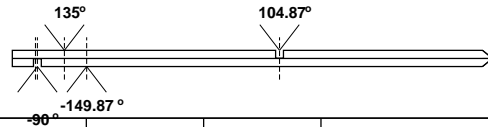
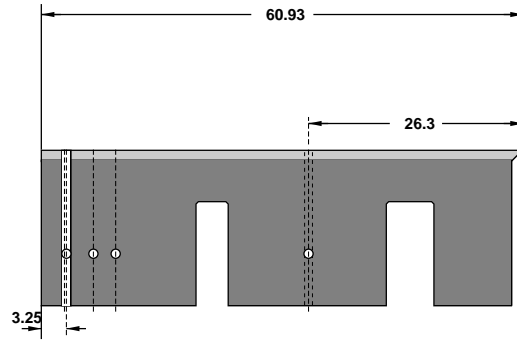
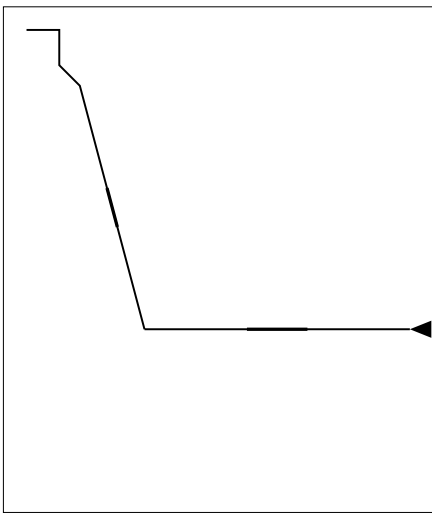

| | | | | | | | | |
|----------|-----------|------------------|------------|-----------|--------------|---------------|---------------------------|----------|
| 9 | Line-No. | Date | 27.02.2012 | Order-No. | | Amount | 25 | Supplier |
| | Path | asercpack/filesW | Author | Yashin A | Height | 23.80 | Laserpack Fryazino | |
| | File | a> ECMA_A2220.d | Customer | | Manufacturer | Boehler | | |
| | 10/15/18 | | Line type | Cut | Material | UNIVERSAL-T30 | | |
| | Sonstiges | | Pointage | 2.00 | Mat. Table | 04 | | Die-Side |

Rule Processing System ACS 100 for ISO 9000

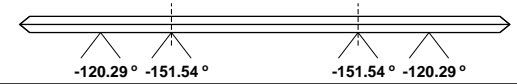
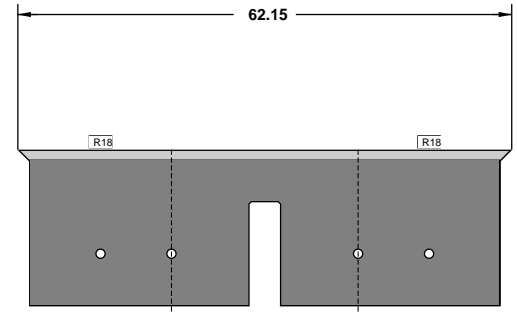
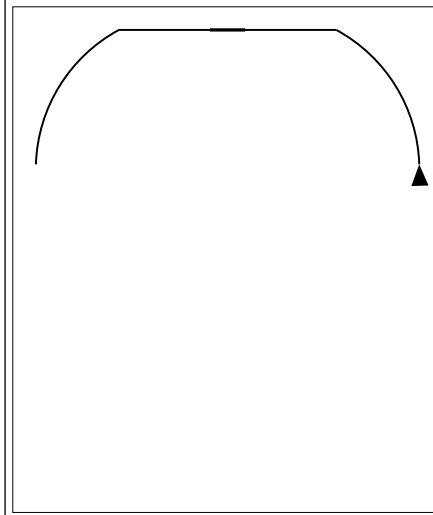

| | | | | | | | | |
|-----------|-----------|------------------|------------|-----------|--------------|---------------|---------------------------|----------|
| 10 | Line-No. | Date | 27.02.2012 | Order-No. | | Amount | 50 | Supplier |
| | Path | asercpack/filesW | Author | Yashin A | Height | 23.80 | Laserpack Fryazino | |
| | File | a> ECMA_A2220.d | Customer | | Manufacturer | Boehler | | |
| | 10/15/18 | | Line type | Cut | Material | UNIVERSAL-T30 | | |
| | Sonstiges | | Pointage | 2.00 | Mat. Table | 04 | | Die-Side |

Rule Processing System ACS 100 for ISO 9000

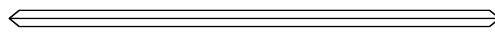
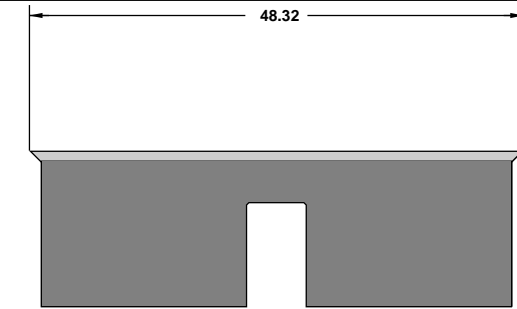
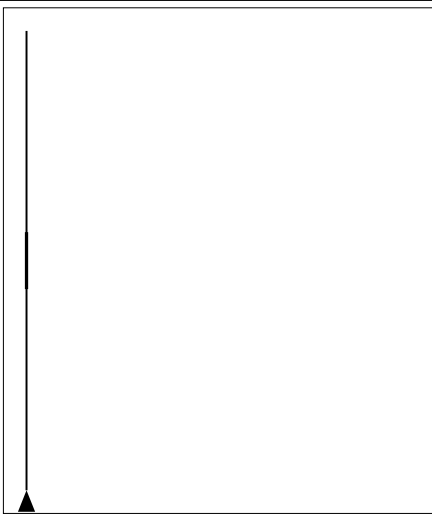

| | | | | | | | | |
|-----------|-----------|------------------|------------|-----------|--------------|---------------|---------------------------|----------|
| 11 | Line-No. | Date | 27.02.2012 | Order-No. | | Amount | 2 | Supplier |
| | Path | asercpack/filesW | Author | Yashin A | Height | 23.80 | Laserpack Fryazino | |
| | File | a> ECMA_A2220.d | Customer | | Manufacturer | Boehler | | |
| | 10/15/18 | | Line type | Cut | Material | UNIVERSAL-T30 | | |
| | Sonstiges | | Pointage | 2.00 | Mat. Table | 04 | | Die-Side |

Rule Processing System ACS 100 for ISO 9000

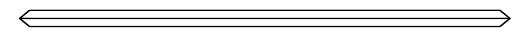
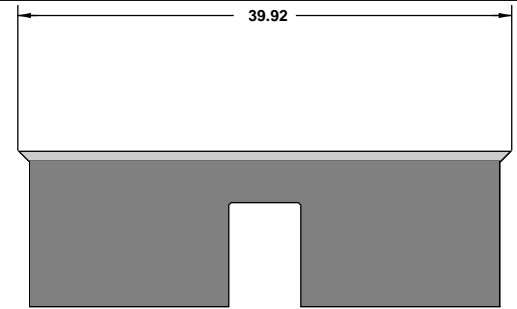

| | | | | | | | | |
|-----------|-----------|------------------|------------|-----------|--------------|---------------|---------------------------|----------|
| 12 | Line-No. | Date | 27.02.2012 | Order-No. | | Amount | 4 | Supplier |
| | Path | asercpack/filesW | Author | Yashin A | Height | 23.80 | Laserpack Fryazino | |
| | File | a> ECMA_A2220.d | Customer | | Manufacturer | Boehler | | |
| | 10/15/18 | | Line type | Cut | Material | UNIVERSAL-T30 | | |
| | Sonstiges | | Pointage | 2.00 | Mat. Table | 04 | | Die-Side |

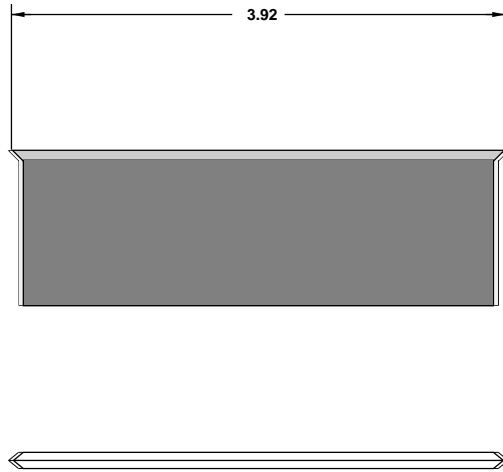
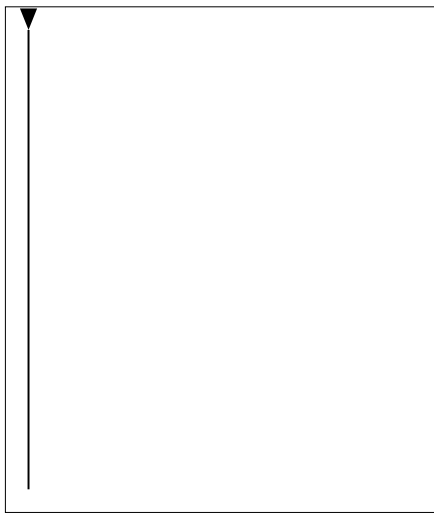

| | | | | | | | | | | |
|-----------|------------------|-----------------|------------------|------------|---------------------|---------------|-----------------|---------------------------|-----------------|--|
| 13 | Line-No. | | Date | 27.02.2012 | Order-No. | | Amount | 6 | Supplier | |
| | Path | aserpack/filesW | Author | Yashin A | Height | | 23.80 | Laserpack Fryazino | | |
| | File | a> ECMA_A2220.d | Customer | | Manufacturer | Boehler | | | | |
| | 10/15/18 | | Line type | Cut | Material | UNIVERSAL-T30 | | | | |
| | Sonstiges | | Pointage | 2.00 | Mat. Table | 04 | Die-Side | | | |

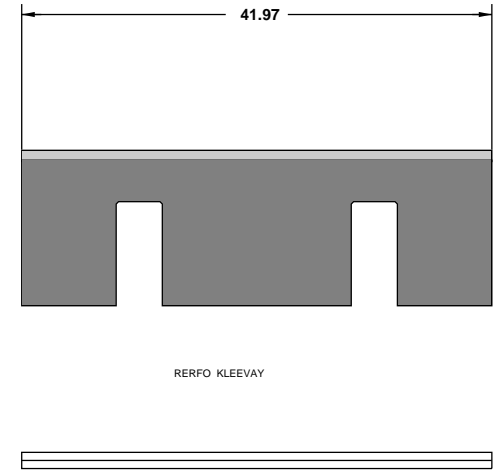
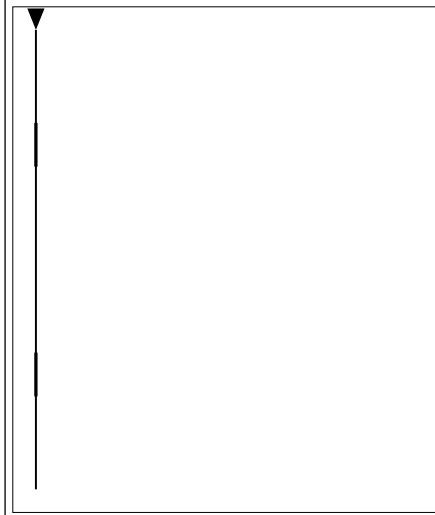

| | | | | | | | | | | |
|-----------|------------------|-----------------|------------------|------------|---------------------|---------------|-----------------|---------------------------|-----------------|--|
| 14 | Line-No. | | Date | 27.02.2012 | Order-No. | | Amount | 25 | Supplier | |
| | Path | aserpack/filesW | Author | Yashin A | Height | | 23.60 | Laserpack Fryazino | | |
| | File | a> ECMA_A2220.d | Customer | | Manufacturer | Boehler | | | | |
| | 10/15/18 | | Line type | PERFO | Material | UNIVERSAL-T30 | | | | |
| | Sonstiges | | Pointage | 2.00 | Mat. Table | 04 | Die-Side | | | |

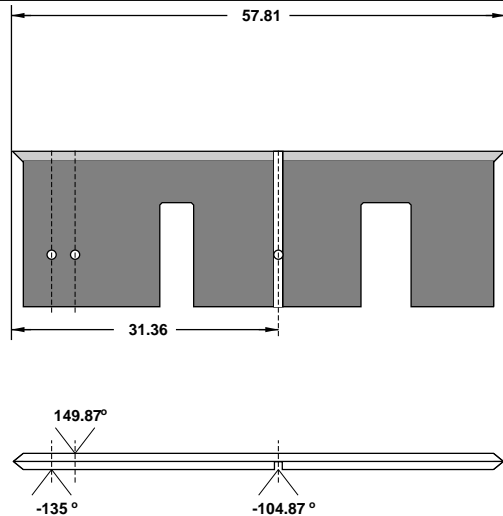
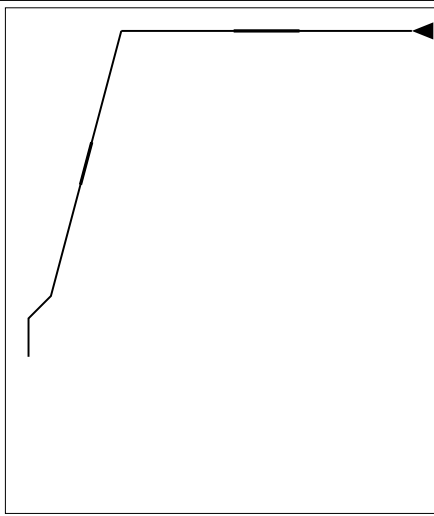

| | | | | | | | | | | |
|-----------|------------------|-----------------|------------------|------------|---------------------|---------------|-----------------|---------------------------|-----------------|--|
| 15 | Line-No. | | Date | 27.02.2012 | Order-No. | | Amount | 50 | Supplier | |
| | Path | aserpack/filesW | Author | Yashin A | Height | | 23.60 | Laserpack Fryazino | | |
| | File | a> ECMA_A2220.d | Customer | | Manufacturer | Boehler | | | | |
| | 10/15/18 | | Line type | Cut | Material | UNIVERSAL-T30 | | | | |
| | Sonstiges | | Pointage | 2.00 | Mat. Table | 04 | Die-Side | | | |

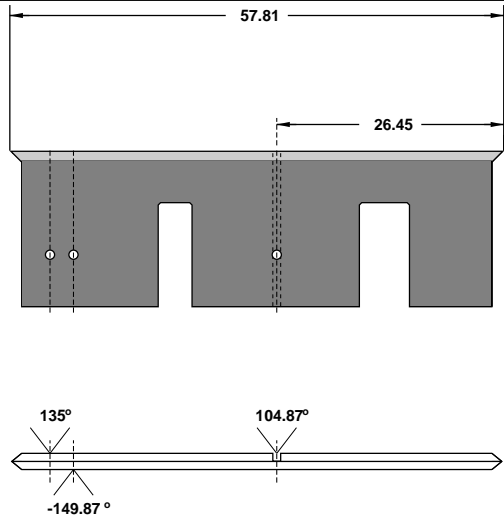
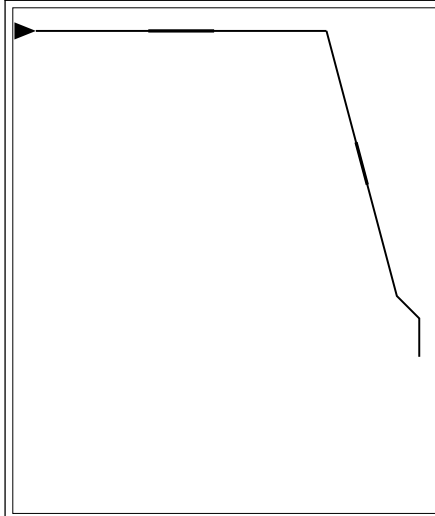

| | | | | | | | | | | |
|-----------|------------------|-----------------|------------------|------------|---------------------|---------------|-----------------|---------------------------|-----------------|--|
| 16 | Line-No. | | Date | 27.02.2012 | Order-No. | | Amount | 25 | Supplier | |
| | Path | aserpack/filesW | Author | Yashin A | Height | | 23.60 | Laserpack Fryazino | | |
| | File | a> ECMA_A2220.d | Customer | | Manufacturer | Boehler | | | | |
| | 10/15/18 | | Line type | Cut | Material | UNIVERSAL-T30 | | | | |
| | Sonstiges | | Pointage | 2.00 | Mat. Table | 04 | Die-Side | | | |

Rule Processing System ACS 100 for ISO 9000

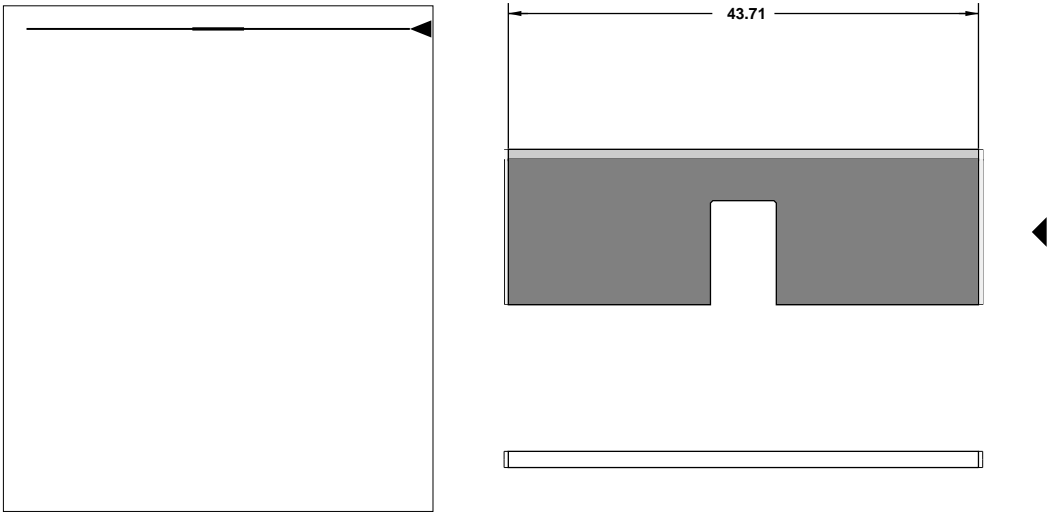

| | | | | | | | | | | |
|-----------|------------------|-------------------|------------------|------------|---------------------|---------------|---------------------------|----|-----------------|--|
| 17 | Line-No. | | Date | 27.02.2012 | Order-No. | | Amount | 50 | Supplier | |
| | Path | aserpack/filesW | Author | Yashin A | Height | 23.30 | Laserpack Fryazino | | | |
| | File | a> ECMA_A2220.doc | Customer | | Manufacturer | Boehler | | | | |
| | 10/15/18 | | Line type | Crease | Material | UNIVERSAL-T30 | | | | |
| | Sonstiges | | Pointage | 2.00 | Mat. Table | 04 | Die-Side | | | |
| | | | | | | | | | | |

Rule Processing System ACS 100 for ISO 9000

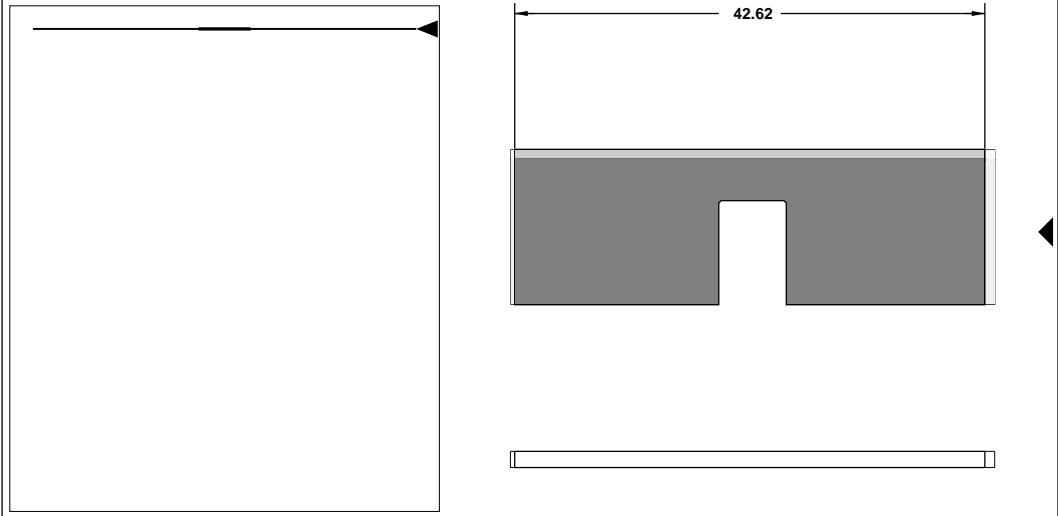

| | | | | | | | | | | |
|-----------|------------------|-------------------|------------------|------------|---------------------|---------------|---------------------------|----|-----------------|--|
| 18 | Line-No. | | Date | 27.02.2012 | Order-No. | | Amount | 50 | Supplier | |
| | Path | aserpack/filesW | Author | Yashin A | Height | 23.30 | Laserpack Fryazino | | | |
| | File | a> ECMA_A2220.doc | Customer | | Manufacturer | Boehler | | | | |
| | 10/15/18 | | Line type | Crease | Material | UNIVERSAL-T30 | | | | |
| | Sonstiges | | Pointage | 2.00 | Mat. Table | 04 | Die-Side | | | |
| | | | | | | | | | | |

Rule Processing System ACS 100 for ISO 9000

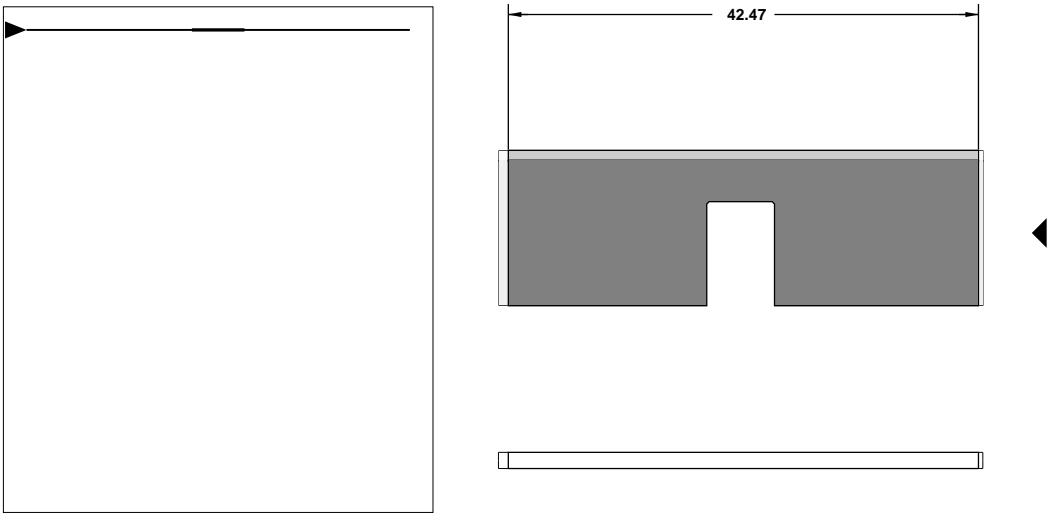

| | | | | | | | | | | |
|-----------|------------------|-------------------|------------------|------------|---------------------|---------------|---------------------------|----|-----------------|--|
| 19 | Line-No. | | Date | 27.02.2012 | Order-No. | | Amount | 25 | Supplier | |
| | Path | aserpack/filesW | Author | Yashin A | Height | 23.30 | Laserpack Fryazino | | | |
| | File | a> ECMA_A2220.doc | Customer | | Manufacturer | Boehler | | | | |
| | 10/15/18 | | Line type | Crease | Material | UNIVERSAL-T30 | | | | |
| | Sonstiges | | Pointage | 2.00 | Mat. Table | 04 | Die-Side | | | |
| | | | | | | | | | | |

Rule Processing System ACS 100 for ISO 9000

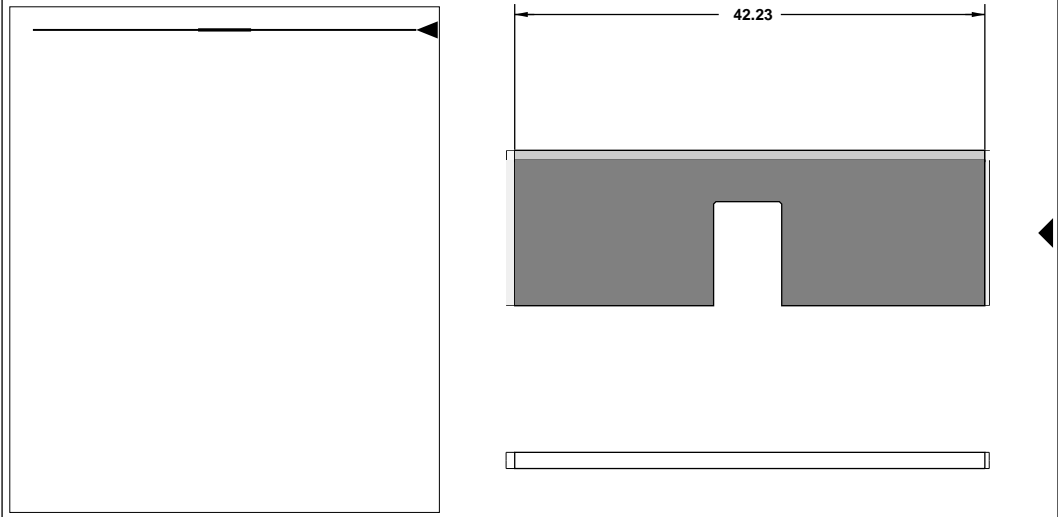

| | | | | | | | | | | |
|-----------|------------------|-------------------|------------------|------------|---------------------|---------------|---------------------------|----|-----------------|--|
| 20 | Line-No. | | Date | 27.02.2012 | Order-No. | | Amount | 25 | Supplier | |
| | Path | aserpack/filesW | Author | Yashin A | Height | 23.30 | Laserpack Fryazino | | | |
| | File | a> ECMA_A2220.doc | Customer | | Manufacturer | Boehler | | | | |
| | 10/15/18 | | Line type | Crease | Material | UNIVERSAL-T30 | | | | |
| | Sonstiges | | Pointage | 2.00 | Mat. Table | 04 | Die-Side | | | |
| | | | | | | | | | | |

Rule Processing System ACS 100 for ISO 9000

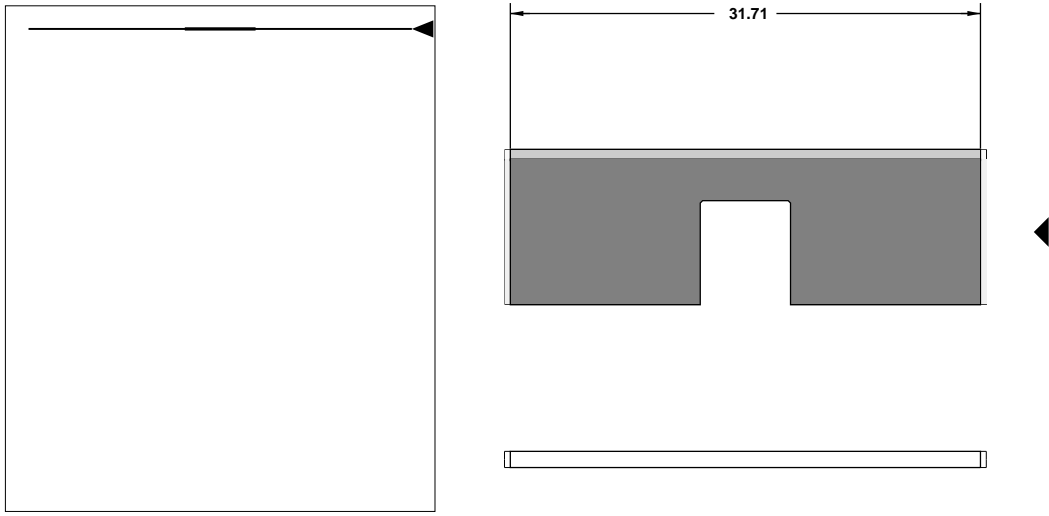

| | | | | | | | | | | |
|-----------|------------------|-----------------|------------------|------------|---------------------|---------------|---------------------------|----|-----------------|--|
| 21 | Line-No. | | Date | 27.02.2012 | Order-No. | | Amount | 50 | Supplier | |
| | Path | aserpack/filesW | Author | Yashin A | Height | 23.30 | Laserpack Fryazino | | | |
| | File | a> ECMA_A2220.d | Customer | | Manufacturer | Boehler | | | | |
| | 10/15/18 | | Line type | Crease | Material | UNIVERSAL-T30 | | | | |
| | Sonstiges | | Pointage | 2.00 | Mat. Table | 04 | Die-Side | | | |
| | | | | | | | | | | |

Rule Processing System ACS 100 for ISO 9000

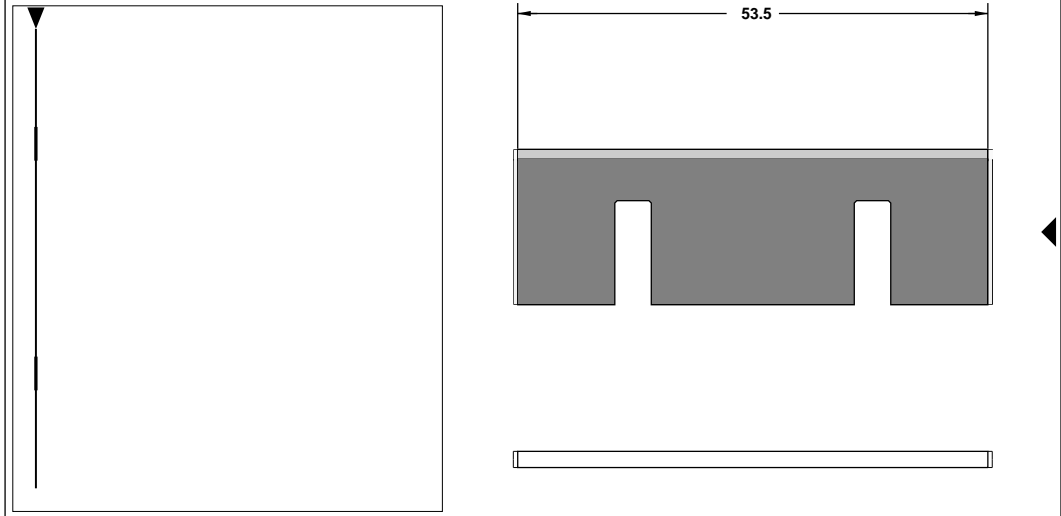

| | | | | | | | | | | |
|-----------|------------------|-----------------|------------------|------------|---------------------|---------------|---------------------------|----|-----------------|--|
| 22 | Line-No. | | Date | 27.02.2012 | Order-No. | | Amount | 25 | Supplier | |
| | Path | aserpack/filesW | Author | Yashin A | Height | 23.30 | Laserpack Fryazino | | | |
| | File | a> ECMA_A2220.d | Customer | | Manufacturer | Boehler | | | | |
| | 10/15/18 | | Line type | Crease | Material | UNIVERSAL-T30 | | | | |
| | Sonstiges | | Pointage | 2.00 | Mat. Table | 04 | Die-Side | | | |
| | | | | | | | | | | |

Rule Processing System ACS 100 for ISO 9000

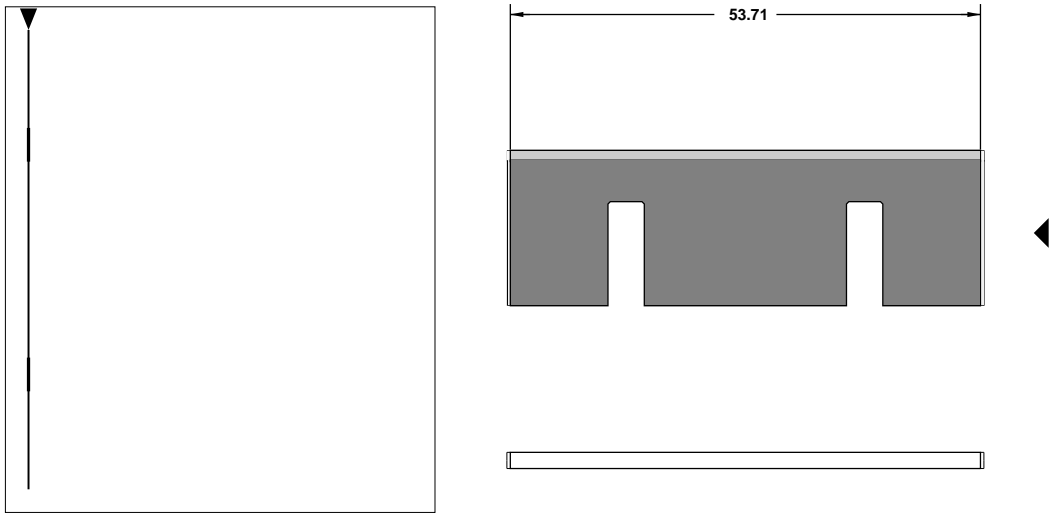

| | | | | | | | | | | |
|-----------|------------------|-----------------|------------------|------------|---------------------|---------------|---------------------------|----|-----------------|--|
| 23 | Line-No. | | Date | 27.02.2012 | Order-No. | | Amount | 75 | Supplier | |
| | Path | aserpack/filesW | Author | Yashin A | Height | 23.30 | Laserpack Fryazino | | | |
| | File | a> ECMA_A2220.d | Customer | | Manufacturer | Boehler | | | | |
| | 10/15/18 | | Line type | Crease | Material | UNIVERSAL-T30 | | | | |
| | Sonstiges | | Pointage | 2.00 | Mat. Table | 04 | Die-Side | | | |
| | | | | | | | | | | |

Rule Processing System ACS 100 for ISO 9000



complete list

| Date | File | Order-No. | Author | Customer | Up |
|------------|-------------------|-----------|----------|----------|----|
| 27.02.2012 | a> ECMA_A2220.dds | | Yashin A | | 1 |

| No. | Line type | Height | Point. | Amount | Bridges | | BEMDMARK | | KBends | | Broaching | | Length | Sum | Total | Manufacturer | Mat. Table |
|-----|-----------|--------|--------|--------|---------|-----|----------|-----|--------|-----|-----------|-----|--------|---------|---------|--------------|------------|
| | | | | | Sing. | Sum | Sing. | Sum | Sing. | Sum | Sing. | Sum | | | | | |
| 1 | Cut | 23.80 | 2.00 | 2 | 14 | 28 | 0 | 0 | 0 | 0 | 0 | 0 | 952.50 | 1905.00 | | Boehler | 04 |
| 2 | Cut | 23.80 | 2.00 | 5 | 2 | 10 | 0 | 0 | 0 | 0 | 2 | 10 | 57.54 | 287.70 | 2192.70 | Boehler | 04 |
| 3 | PERFO | 23.80 | 2.00 | 25 | 1 | 25 | 3 | 75 | 3 | 75 | 3 | 75 | 66.50 | 1662.50 | | Boehler | 04 |
| 4 | PERFO | 23.80 | 2.00 | 50 | 2 | 100 | 4 | 200 | 4 | 200 | 3 | 150 | 85.14 | 4257.00 | | Boehler | 04 |
| 5 | PERFO | 23.80 | 2.00 | 25 | 2 | 50 | 4 | 100 | 4 | 100 | 3 | 75 | 85.14 | 2128.50 | 8048.00 | Boehler | 04 |
| 6 | Cut | 23.80 | 2.00 | 25 | 1 | 25 | 0 | 0 | 0 | 0 | 0 | 0 | 46.36 | 1159.00 | | Boehler | 04 |
| 7 | Cut | 23.80 | 2.00 | 25 | 3 | 75 | 2 | 50 | 2 | 50 | 2 | 50 | 85.61 | 2140.25 | | Boehler | 04 |
| 8 | Cut | 23.80 | 2.00 | 25 | 1 | 25 | 1 | 25 | 1 | 25 | 0 | 0 | 58.70 | 1467.50 | | Boehler | 04 |
| 9 | Cut | 23.80 | 2.00 | 25 | 2 | 50 | 4 | 100 | 4 | 100 | 2 | 50 | 60.93 | 1523.25 | | Boehler | 04 |
| 10 | Cut | 23.80 | 2.00 | 50 | 1 | 50 | 4 | 200 | 2 | 100 | 0 | 0 | 62.15 | 3107.50 | | Boehler | 04 |
| 11 | Cut | 23.80 | 2.00 | 2 | 1 | 2 | 0 | 0 | 0 | 0 | 0 | 0 | 48.32 | 96.64 | | Boehler | 04 |
| 12 | Cut | 23.80 | 2.00 | 4 | 1 | 4 | 0 | 0 | 0 | 0 | 0 | 0 | 39.92 | 159.68 | | Boehler | 04 |
| 13 | Cut | 23.80 | 2.00 | 6 | 0 | 0 | 0 | 0 | 0 | 0 | 0 | 0 | 3.92 | 23.52 | 9677.34 | Boehler | 04 |
| 14 | PERFO | 23.60 | 2.00 | 25 | 2 | 50 | 0 | 0 | 0 | 0 | 0 | 0 | 41.97 | 1049.25 | 1049.25 | Boehler | 04 |
| 15 | Cut | 23.60 | 2.00 | 50 | 2 | 100 | 3 | 150 | 3 | 150 | 1 | 50 | 57.81 | 2890.50 | | Boehler | 04 |
| 16 | Cut | 23.60 | 2.00 | 25 | 2 | 50 | 3 | 75 | 3 | 75 | 1 | 25 | 57.81 | 1445.25 | 4335.75 | Boehler | 04 |
| 17 | Crease | 23.30 | 2.00 | 50 | 1 | 50 | 0 | 0 | 0 | 0 | 0 | 0 | 43.71 | 2185.50 | | Boehler | 04 |
| 18 | Crease | 23.30 | 2.00 | 50 | 1 | 50 | 0 | 0 | 0 | 0 | 0 | 0 | 42.62 | 2131.00 | | Boehler | 04 |
| 19 | Crease | 23.30 | 2.00 | 25 | 1 | 25 | 0 | 0 | 0 | 0 | 0 | 0 | 42.47 | 1061.75 | | Boehler | 04 |
| 20 | Crease | 23.30 | 2.00 | 25 | 1 | 25 | 0 | 0 | 0 | 0 | 0 | 0 | 42.23 | 1055.75 | | Boehler | 04 |

complete list

| Date | File | Order-No. | Author | Customer | Up |
|------------|-------------------|-----------|----------|----------|----|
| 27.02.2012 | a> ECMA_A2220.dds | | Yashin A | | 1 |

| No. | Line type | Height | Point. | Amount | Bridges | | BEMDMAR | | KBends | | Broaching | | Length | Sum | Total | Manufacturer | Mat. Table | |
|-----|-----------|--------|--------|--------|---------|------|---------|-----|--------|-----|-----------|-----|--------|---------|----------|--------------|------------|--|
| | | | | | Sing. | Sum | Sing. | Sum | Sing. | Sum | Sing. | Sum | | | | | | |
| 21 | Crease | 23.30 | 2.00 | 50 | 1 | 50 | 0 | 0 | 0 | 0 | 0 | 0 | 31.71 | 1585.50 | | Boehler | 04 | |
| 22 | Crease | 23.30 | 2.00 | 25 | 2 | 50 | 0 | 0 | 0 | 0 | 0 | 0 | 53.50 | 1337.50 | | Boehler | 04 | |
| 23 | Crease | 23.30 | 2.00 | 75 | 2 | 150 | 0 | 0 | 0 | 0 | 0 | 0 | 53.71 | 4028.25 | 13385.25 | Boehler | 04 | |
| | | | | 669 | | 1044 | | 975 | | 875 | | 485 | | | 38688.29 | | | |